



White Paper

Dynamic Characteristics of Check Valves

Table of Contents

Forward.	2
Introduction.	2
Check Valve Selection.	2
Test Methodology.	4
Test Results.	8
Conclusion	9
References	10

Dynamic Characteristics of Check Valves

Dynamic Characteristics of Check Valves was written to assist the design professional in predicting slam in basic check valves without dashpots and other specialized hydraulic controls. It is not intended to provide all of the information necessary for selecting a check valve but rather to explain in engineering terms the cause of check valve slam and the inherent closing characteristics of various check valves that contribute to this phenomenon.

With this knowledge, the design professional can predict before pump station start-up whether serious check valve problems will occur. Other design issues such as head loss and cost are equally important factors and should be considered in making the final valve selection.

The test data presented offers valuable information for predicting valve performance. It is based on independent tests conducted at the Utah Water Research Laboratory and remains the property of Val-Matic Valve & Mfg. Corp.

Introduction

When bringing a pump station on line for the first time, the design engineer has many concerns such as when the START button is pressed; will the pump produce the rated flow; when the STOP button is pressed; will the check valve slam? Check valve slam can range from a minor nuisance to a building-shaking, neighborhood-disturbing crash. The slam is the water hammer caused by the sudden stopping of reverse flow through the check valve as it closes. Check valve slam can delay final completion and approval of projects for months and therefore warrants careful study and understanding.

Val-Matic performed an exhaustive testing program at Utah Water Research Laboratory on several types of check valves and published this data in the form of dynamic check valve response curves. A methodology was developed to use the check valve data to predict check valve slam. This methodology is a useful tool when combined with field experience to predict check valve problems before the start-up of the pump station. Other design issues such as headloss, reliability, and installed cost are equally important factors and should be considered in making the final check valve selection.

Check Valve Selection

There are several technical papers, valve handbooks, and software design tools available to assist in check valve selection. The process is often difficult because selecting a check valve can involve many criteria such as non-slamming characteristics, headloss characteristics, operating costs, controllability, maintenance costs, and installation laying length. Most of these criteria, however, are straightforward and can be calculated for the various types of check valves available. This methodology will focus on the non-slamming characteristics of check valves and match them to various systems. It is a fact that given a severe pumping application, all check valves will slam to some degree. It is also a fact that in normal applications, various check valves will not slam. It is the unpredictability of the middle ground between these extremes that makes the task of selecting check valves difficult.

Dynamic Characteristics of Check Valves

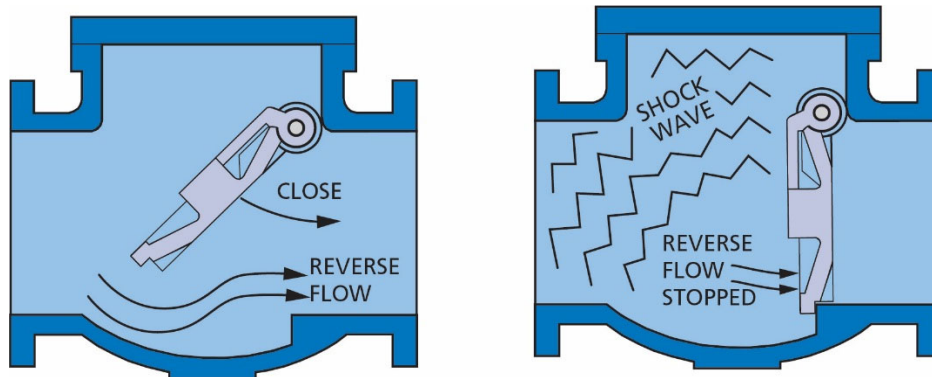

FIGURE 1. Check Valve Slam

Check valve slam occurs after pump stoppage when the system flow reverses back towards the pump before the check valve is fully closed (Figure 1). The reverse flow causes the check valve to close rapidly through the remaining portion of its travel. The reverse flow is then stopped instantaneously by the closed valve causing a loud water hammer in the pipe. The noise associated with the slam is not the impact of the disc into the seat, but rather the rapid stretching of the pipe due to the water hammer. Surprisingly, a resilient-seated check valve can make the same metallic slam sound as a metal-seated valve.

To prevent check valve slam, a check valve must either close very rapidly before appreciable reverse flow occurs or very slowly once reverse-flow has developed. In order to close rapidly, studies (Thorley, 180) indicate that:

- the disc should have low inertia and friction,
- the travel of the disc should be short, or
- the motion should be assisted with springs.

To close slowly, a check valve needs to be equipped with external devices such as oil dashpots and the pump must be capable of withstanding some backspin. Oil dashpot devices have proven to be effective, but are beyond the scope of this methodology. The answer to preventing check valve slam is not to find the fastest closing check valve and make it the “standard”. Instead, the non-slam characteristics of the check valve must be matched with the pumping system. Every check valve has inherent advantages such as low cost, low headloss, or special flow characteristics. The best check valve is not necessarily the one with the least potential to slam.

Probably the simplest pumping system is a water well application consisting of a single pump operating at low pressure and sending water to a ground reservoir several thousand feet distant. Because of the low operating pressure and high friction, after pump stoppage the flow will reverse or decelerate slowly. The rate at which the flow reverses, however, is important in gauging whether the check valve will slam. For a low head application with a long pipe length, there is less potential for rapid flow reversal and the simplest and lowest cost check valve may be used without slamming. On the other hand, a multiple-pump station sending water to a high head system with a nearby elevated or pneumatic surge tank will experience an extremely rapid flow reversal and only certain check valves can be used without slamming.

Dynamic Characteristics of Check Valves

To select a non-slam check valve, the pump station designer must first analyze the pumping system and calculate the deceleration of the liquid column after pump stoppage. In other words, if the flow rate is 12 ft/sec and calculations show that the flow will stop in 2 seconds, then the average deceleration is 12 ft/sec divided by 2 sec or 6.0 ft/sec². Calculating the deceleration can be difficult because it is a function of many parameters such as pump inertia (provided by the pump manufacturer), length of the liquid column, friction losses in the piping system, and the static head or slope of the pipe. Engineers typically rely on a computer simulation of the system to compute deceleration.

It is the responsibility of the valve manufacturer to provide the dynamic characteristics of their valves so that the engineer can predict the maximum reverse velocity that may occur. It is suggested that for each type of check valve, a response curve should be generated to show the relationship between the deceleration of the liquid column and the maximum reverse velocity through the check valve (Provoost, 278). The deceleration is expressed in terms of dv/dt or change in forward velocity divided by change in time or ft/sec². The reverse velocity is developed from testing and is expressed in velocity terms or ft/sec.

For example, dynamic test data for a dual-plate wafer check valve is shown in Figure 2. The horizontal axis represents the deceleration of the piping system expressed in feet per second squared. The vertical axis is the maximum reverse velocity through the check valve expressed in feet per second. A single-pump, low-head system will have a deceleration of less than 20 ft/sec². A high-head system of a multiple-pump system may have a deceleration as high as 40 ft/sec². For this higher deceleration, the dual plate check valve of Figure 2 will allow a reverse velocity to develop equal to about 1.0 ft/sec. The reverse velocity can be converted directly into water hammer pressure using the equation [AWWA, 51]:

$$h = \frac{a v}{g}$$

Where:

- h = pressure rise, ft of water
- a = wave velocity, ft/sec \approx 3200 ft/sec (steel pipe)
- v = reverse velocity, ft/sec
- g = 32.2 ft ft/sec²

The reverse flow of 1.0 ft/sec corresponds to a water hammer of 100 ft (43 psi). Field experience shows that water hammers in the range of 50 to 100 ft (or reverse velocities of 0.5 to 1.0 ft/sec) represent a mild slam and can be tolerated. Conversely, water hammers over 100 ft (or reverse velocities over 1.0 ft/sec) are extremely loud and should be avoided by either selecting a different check valve or modifying the check valve with heavier springs or hydraulic dashpots.

Dynamic Characteristics of Check Valves

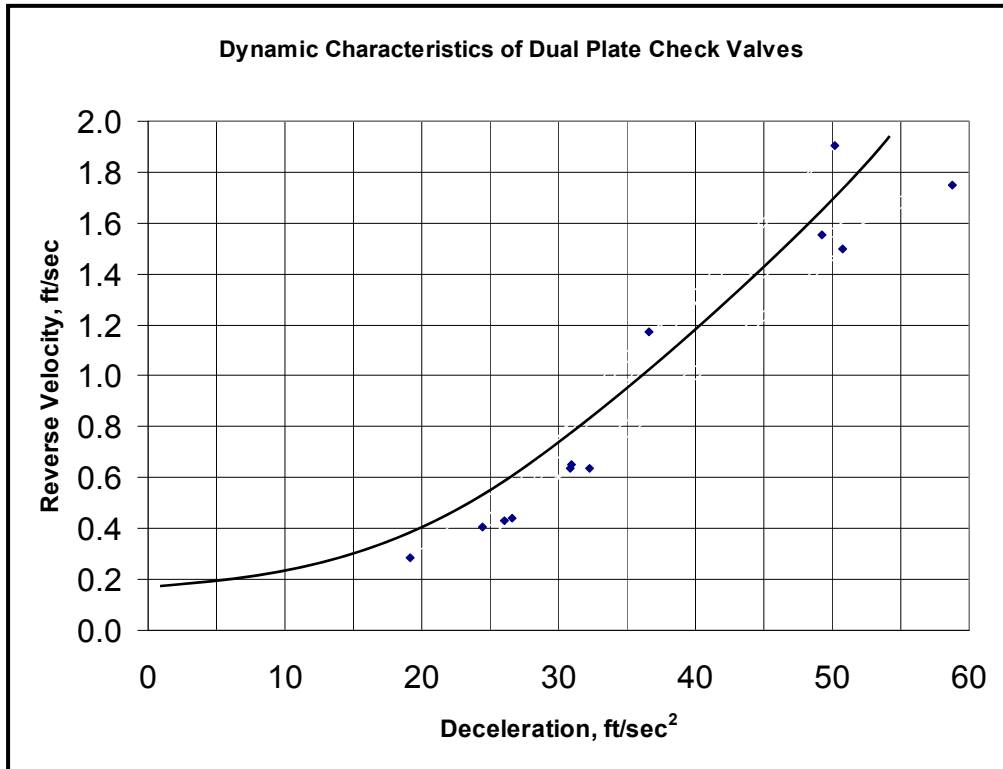

FIGURE 2. Dynamic Test Data

Test Methodology

To develop dynamic characteristics for its check valves, Val-Matic contracted a series of valve flow tests at the Utah Water Research Laboratory in Logan, Utah. Several types of eight-inch check valves were water flow tested under dynamic conditions.

The check valves were installed in a horizontal test piping run and subjected to different initial forward flows and varying rates of flow reversals. The lab is supplied with a natural supply of mountain runoff water from a reservoir through a 48 inch pipeline so velocities in the range of four to twenty feet per second were easily attained. The lab is also equipped with a certified weigh tank system to record flow rates. Valve head loss was read using manometers and dynamic pressures were recorded using transducers and a high-speed data recorder.

Dynamic Characteristics of Check Valves

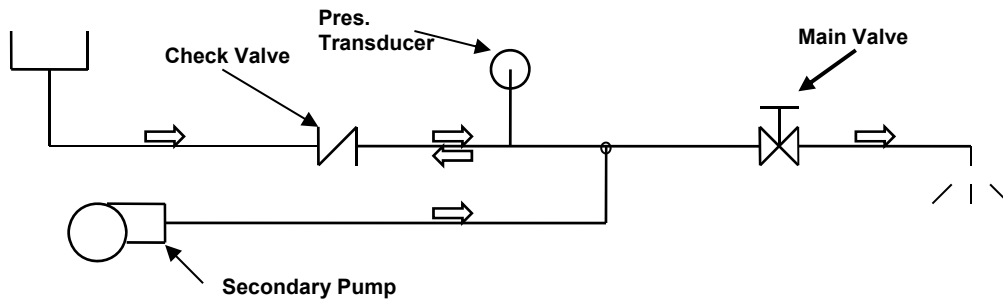

FIGURE 3. Check Valve Test Loop

Forward flow from the reservoir was established by opening the main valve shown in Figure 3. The supply flow at about 5 psig from the reservoir automatically opened the check valve fully and flow rates and headloss data were recorded. Next, a secondary pump was started to supply additional flow at a higher pressure of about 20 psig. Both flows merged downstream of the check valve and exited through the Main Valve.

To trigger a check valve slam, the main valve was suddenly closed stopping the forward flow and the secondary pump would rapidly produce reverse flow and valve slam. Different rates of deceleration were achieved by closing the main valve at different rates.

The pressure downstream of the valve was recorded and used to calculate the deceleration of the flow and the reverse velocity through the valve. A sample computer trace is shown in Figure 4.

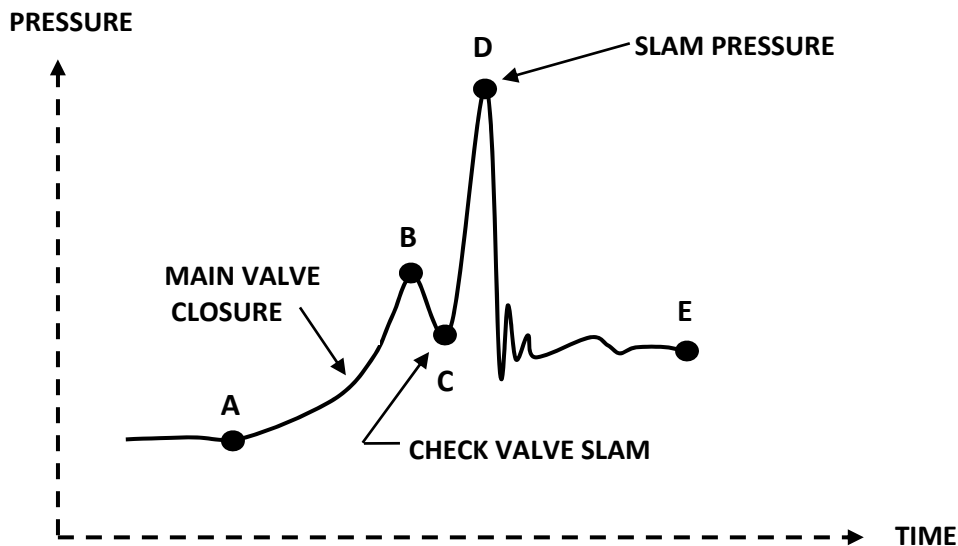

FIGURE 4. Sample Pressure Recording

Dynamic Characteristics of Check Valves

The sequence associated with Figure 4 above is as follows:

- A = reservoir pressure
- A-B = main valve is closed stopping forward flow, check valve starts to close
- B = flow is stopped, check valve continues to close
- B-C = reverse flow builds
- C = valve disc strikes the seat causing slam and water hammer
- D = water hammer pressure resulting from sudden reverse flow stoppage
- E = secondary pump pressure

Average decelerations were calculated by dividing the initial velocity by the A-B time interval. The reverse flow velocity was calculated based on the surge pressure measured between points C and D and the equation given on page 6.

This test methodology has been applied by different researchers to many types of check valves. For example, Thorley (p. 23) tested and reported results for common ball check and swing check valves as shown in Figures 5 and 6. Provoost tested nozzle check valves in similar fashion as shown in Figure 7.

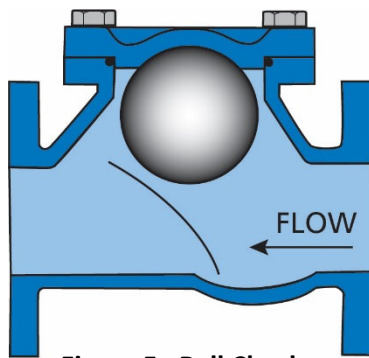

Figure 5. Ball Check

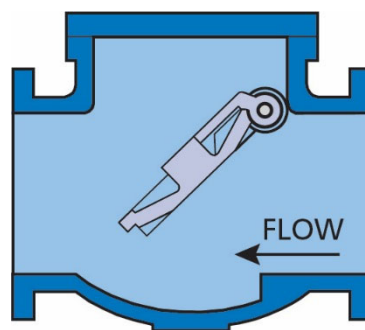

Figure 6. Swing Check

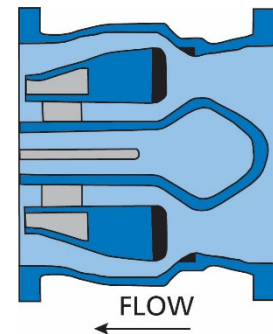
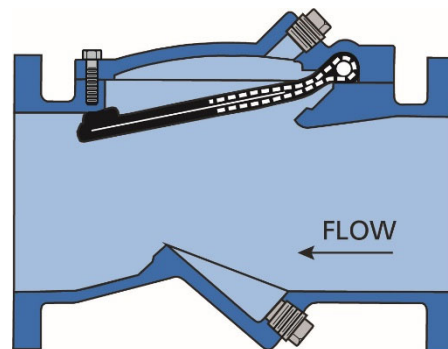

Figure 7. Nozzle Check

The test methodology was applied to five 8-inch flanged Val-Matic production check valves as shown in Figures 8 through 12 (Rahmeyer):

Figure 8. Val-Matic Model 508A Swing-Flex® Check Valve (SFCV).

The SFCV features a resilient hinged disc, angled seat, and short stroke.



Dynamic Characteristics of Check Valves

Figure 9. Val-Matic Model 9808 Tilted Disc® Check Valve (TDCV).

This valve features an offset butterfly type disc, angled seat, short stroke, and 140% port area for the lowest possible headloss.

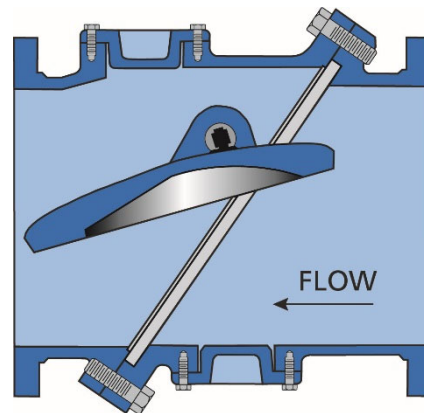

Figure 10. Model 8808W Dual Disc® Check Valve (DDCV).

The DDCV features two half-circle discs that pivot closed with the assistance of a strong torsion spring.

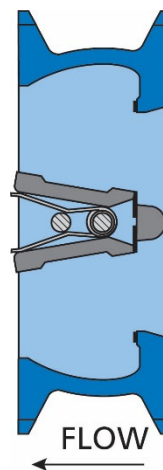

Figure 11. Model 7208 Surgebuster® Swing Check Valve (SB).

The Surgebuster® (SB) features a resilient hinged disc, angled seat, and short stroke, and a disc accelerator.

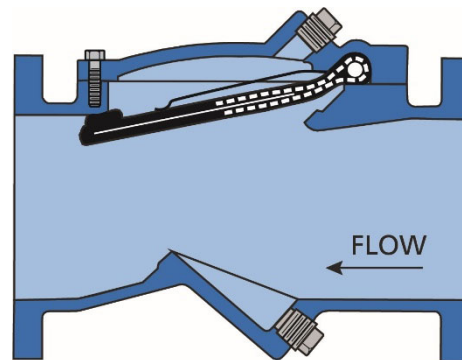
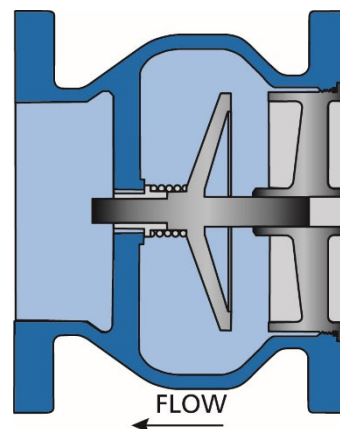

Figure 12. Model 1808A Globe-Style Silent Check Valve (SCV).

The SCV features a short linear stroke with a strong return spring.



Dynamic Characteristics of Check Valves

Test Results

The test results for these valves are presented in graph form in Figure 13 together with similar data for swing check, ball check (Thorley, 23), and nozzle check (Noreva). The results clearly indicate that the best non-slam check valves are the Nozzle Check Valve, Dual Disc[®] Check Valve, Surgebuster[®], and the Silent Check Valve, which all feature spring-assisted closure. The next best non-slam check valves are the Swing-Flex[®] Check Valve and Tilted Disc[®] Check Valve, which feature an angled seat and short stroke. Finally, the valves with long strokes and no spring assist, the ball check and swing check, have the greatest potential for slamming.

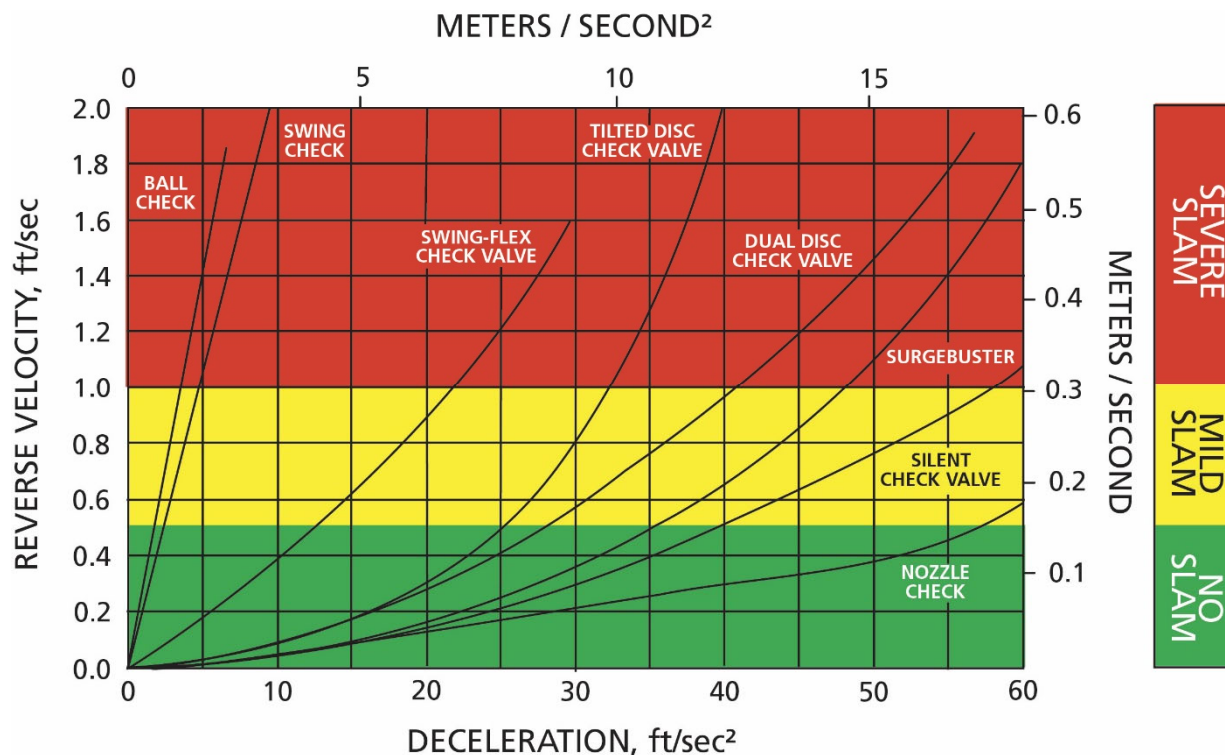

FIGURE 13. Dynamic Characteristics of Various Check Valves

The chart was divided into three ranges: NO SLAM, MILD SLAM, and SEVERE SLAM. These divisions are based on numerous field observations of valve slams and acceptable levels of noise and disturbance to the valve and pumping system. The designer can also convert the given reverse velocity to a quantitative surge pressure using the equation on page 4 and make a separate determination of system impact.

The designer uses Figure 13 by finding the system deceleration on the horizontal axis and then reading the reverse velocity for the various types of check valves. For example, given a multiple pump station with a calculated system deceleration is 30 ft/sec², the following predictions can be read from the graph:

Dynamic Characteristics of Check Valves

Valve Type	Reverse Velocity	Type of Slam
Nozzle Check Valve	.20 ft/sec	none
Silent Check	.33 ft/sec	none
Surgebuster [®] Swing Check	.44 ft/sec	none
Dual Disc [®] Check	.60 ft/sec	mild
Tilted Disc [®] Check	.80 ft/sec	mild
Swing-Flex [®] Check	1.8 ft/sec	severe
Ball Check	>2.0 ft/sec	severe
Swing Check	>2.0 ft/sec	severe

The designer can go on to calculate an estimated slam pressure on the basis that there is about 100 ft of water hammer for every 1 ft/sec of reverse velocity. In the example above, the Surgebuster[®] would produce a slam pressure of about 0.44×100 or a 44 ft (19 psi) pressure surge, which would sound like a dull thud upon closure.

However, the designer can still consider using one of the valves in the “mild” or “severe” slam ranges by possibly changing to a speed-controlled pump or modifying the valve to include a stronger spring or an oil dashpot. At first glance, it may seem impractical to do so, but a characteristic of one of the valves such as the low headloss of a Tilted Disc[®] Check Valve may be important for this application and an oil dashpot could be economically justified.

Finally, it is important to note some limitations of using the dynamic characteristic data presented in Figure 2. First, the test data is based on installation in a horizontal pipeline. Some valves rely on gravity to accelerate disc closure such as the SWING, TDCV, and SFCV valves and when installed in a vertical pipe, may have a greater tendency to slam. Conversely, other valves such as the DDCV and the SCV will close faster in a vertical line due to gravity effects on their discs and have a lesser tendency to slam. Also, the dynamic characteristics of the valve are dependent on valve size but no data is available at this time to predict the exact effect of size. Larger valves have heavier discs and longer strokes and will likely produce somewhat higher reverse velocities than predicted from Figure 13. The manufacturer should be consulted for the potential impact of orientation and size on the performance of the selected valve.

Conclusion

It should be clear that dynamic characteristic data for check valves only offers the designer the tools necessary to evaluate the non-slam characteristics of various check valves. This information, combined with other readily available valve characteristics such as headloss, laying length, waterway design for fluids containing solids, and cost will provide the designer with all of the tools necessary to make reliable valve selections.

References

1. American Water Works Association, (1989). *Steel Pipe Manual M11*, 3rd edition, Denver, CO, 51-56.
2. Ballun, John V., (2007). A Methodology for Predicting Check Valve Slam, *Journal AWWA*, March 2007, 60-65.
3. Provoost, G.A., (1983). A critical analysis to determine dynamic characteristics of non-return valves, *Proceedings of the 4th International Conference on Pressure Surges*, Bath England, 275-286.
4. Rahmeyer, William, (1998). Reverse flow testing of eight-inch Val-Matic check valves, *Utah State University Lab Report No. USU-609, Val-Matic Valve Test Report No. 117*, Elmhurst, IL, [CONFIDENTIAL].
5. Thorley, A.R.D., (1991). *Fluid Transients in Pipeline Systems*, D&L George Ltd, Hadley Wood, England, 22-23.
6. Thorley, A.R.D. (1989), Check valve behavior under transient flow conditions: a state-of-the-art review. *Journal of Fluids Engineering* 111, 178-183, Fairfield, NJ.

Disclaimer

Val-Matic White Papers are written to train and assist design engineers in the understanding of valves and fluid systems. Val-Matic offers no warranty or representation as to design information and methodologies in these papers. Use of this material should be made under the direction of trained engineers exercising independent judgement.